

# MINI PLANT BALL VALVE

TYPE 300 P, ¼" - 2", PN 63

sampling tube with 2mm inside diameter

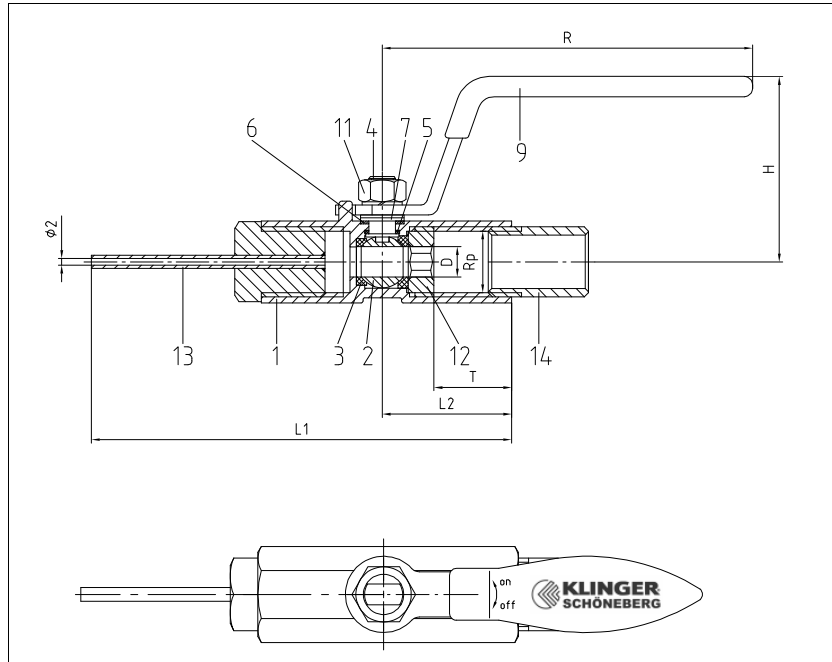

Mini plant ball valve  
female threaded ends acc. to  
EN 10226-1 with  
screwed butt end connection  
sampling tube with 2mm inside diameter  
face to face dimensions acc. to  
producers standard

### Specification:

One-piece sampling device ball valve,  
female threaded ends acc. to EN 10226-1  
with screwed butt weld end connection,  
sampling tube with 2mm inside diameter,  
blow-out-proof stem, body material  
stainless steel (1.4408), free of non ferrous  
metals, with lever.

Marking: TYPE 300 P  
Type: TYPE 300 P-1.4408

No.	Part	Material
1	body	1.4408
2	ball	1.4408
3	seat	KFG
4	stem	1.4401
5	friction washer	KF
6	packing ring	KF
7	thrust washer	1.4301
9	lever	1.4301
11	hex. nut	1.4401
12	inscrewed part	1.4401
13	sampling tube	1.4571
14	screwed butt weld end connection	1.4571

### Dimensions

DN	D	dimensions (mm)				
		L1	L2	T	H	R
¼"	5.0	150	25	11	47	67
⅜"	7.0	170	30	13	49	67
½"	9.0	180	38	14	57	90
¾"	12.5	191	40	18	60	90
1"	16.0	202	45	22	68	112
1 ¼"	20.0	221	55	22	70	112
1 ½"	24.5	231	60	22	75	132
2"	32.0	252	70	23	80	132

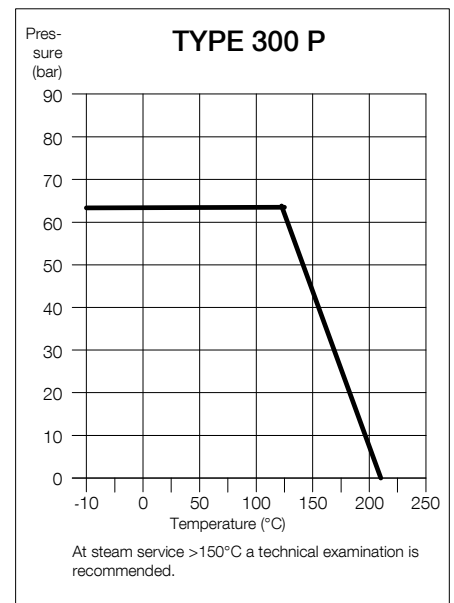

Ordering example:  
TYPE 300 P, 1", PN 63, 1.4408